

A
B
C
D
E
F

A
B
C
D
E
F

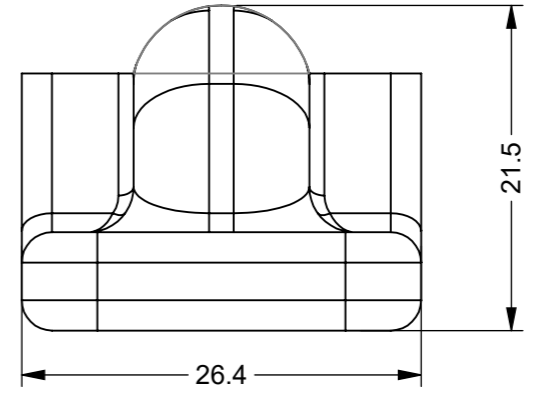
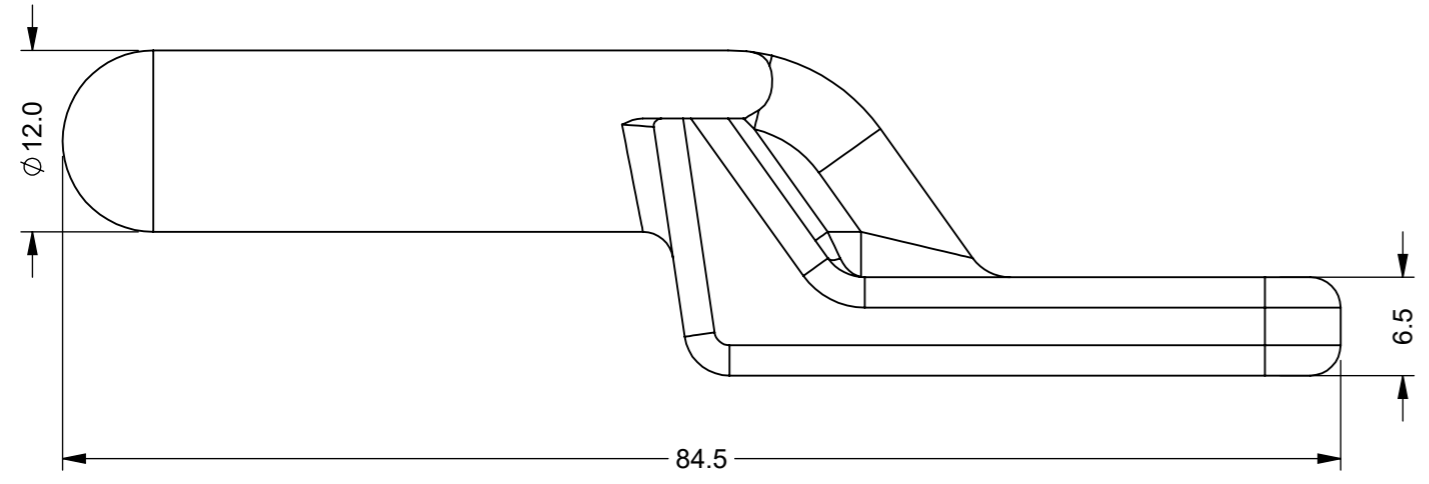
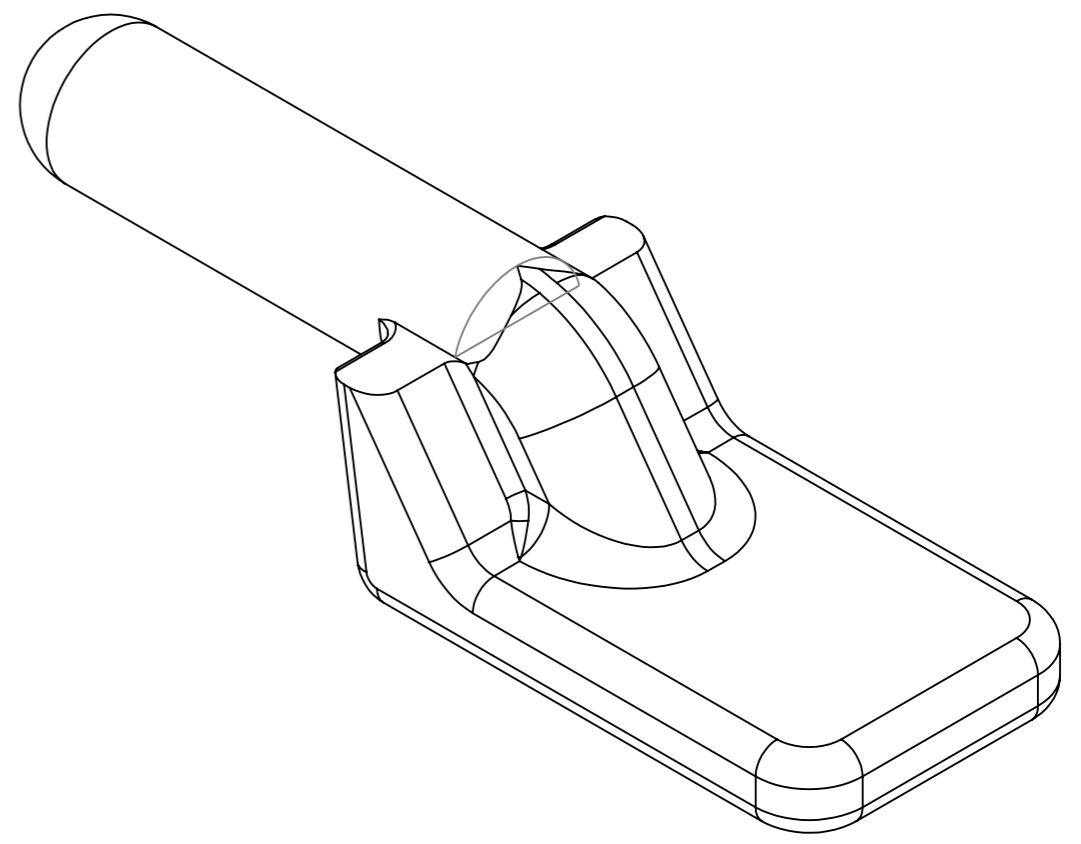
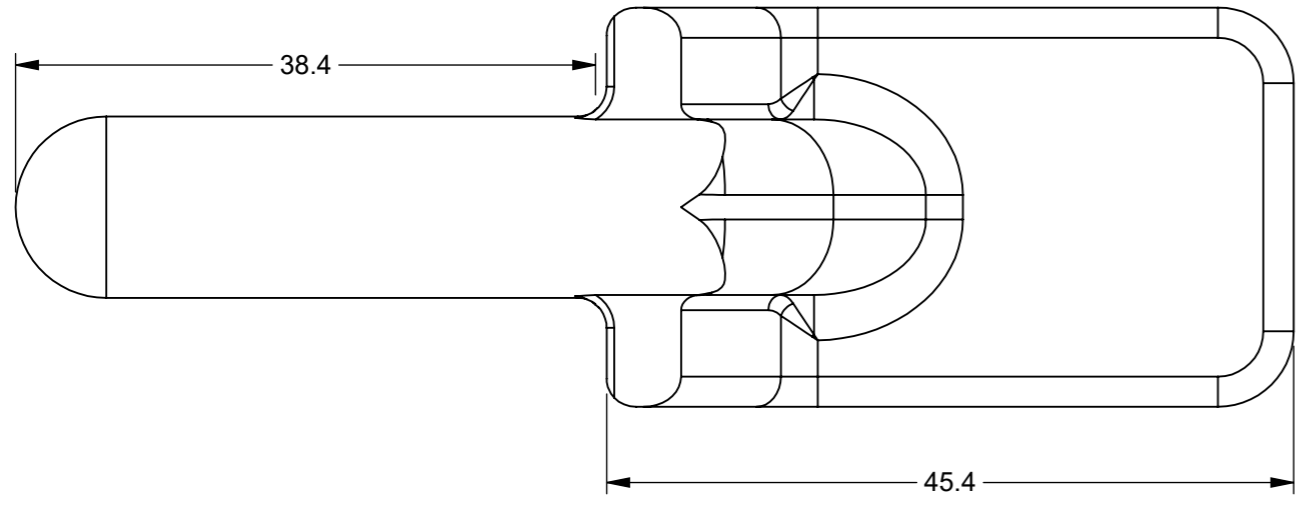

	1	VALIDATION COMPLETE	05/03/2024	AP
ZONE	REV.	DESCRIPTION	DATE	APPROVED

REVISIONS

UNLESS OTHERWISE STATED, ALL DIMENSIONS IN mm

TOLERANCES		SURFACE FINISH 1.6µm Ra	
0.5 - 6	= ±0.1mm	FILLET RADII	0.5 TO 1.0
6 - 30	= ±0.2 mm	SQUARENESS	0.05 IN 25
30 - 120	= ±0.3 mm	PARALLELISM	0.05 IN 25
120 - 400	= ±0.5 mm	RUNOUT	0.1
400 - 1000	= ±0.8 mm	ANGLES	±0.5°
1000 - 2000	= ±1.2 mm		
2000 - 4000	= ±2.0 mm		

MATERIAL: M/STEEL
 MASS: 0.12KG
 FINISH: SELF COLOUR

DRAWN BY: SR
 CHECKED BY: AP
 DESCRIPTION: TAILBOARD GUDGEON PIN

A3

APPROVED BY: AP
 ORIGINATION DATE: 04/03/2024
 NUMBER: 1036-001
 REVISION: 1
 SHEET: 1 of 1

SCALE : PROPORTIONAL - DO NOT SCALE
 REF SCALE 1:1 WHEN PRINTED ON A3
 PROJECTION 3rd ANGLE

PROPRIETARY RIGHTS ARE INCLUDED IN THE INFORMATION DISCLOSED HEREIN. NEITHER THIS DOCUMENT NOR ANY INFORMATION DISCLOSED SHALL BE REPRODUCED, USED, TRANSFERRED TO OTHER DOCUMENTS, OR DISCLOSED TO OTHERS FOR ANY PURPOSE INCLUDING MANUFACTURING UNLESS SPECIFICALLY AUTHORISED IN WRITING
 REMOVE ALL SHARP EDGES AND BURRS
 PART FINISHING AND MARKING TO CESF001

